

## Comparative study on Bridge type Negative Luo converter fed BLDC motor drive.

Baiju Antony<sup>1</sup>, Gomathy S<sup>2</sup>

<sup>1</sup>(Department of Electrical and Electronics Engineering, Adi Shankara Institute of Engineering and Technology  
A P J Abdul Kalam University, India)

<sup>2</sup>(Department of Electrical and Electronics Engineering, Adi Shankara Institute of Engineering and Technology  
A P J Abdul Kalam University, India)

**Abstract:** Motors are an integral components of every moving equipment's that we use for different types of moving applications. There are several types of motors available for all these applications, But among all these types of motors the benefits of BLDC motors in low and medium power applications is proven to be much efficient than the other type motors considering the factors like high flux density per unit volume, high efficiency, silent operation, low electromagnetic interference and low maintenance requirements. In Permanent Magnet BLDC motors comparing to the conventional induction motor instead of using brush type commutation we utilize a three-phase voltage-source inverter controlled by a switching control. A Diode bridge rectifier is utilized to provide DC voltage to the voltage source inverter. But, the Power Factor at the input source will be much less than ideal unity Power Factor at this condition and in order to solve this issue we use a Power Factor Correction circuit to improve this power factor. Bridge type Luo converter and Ultra-Luo converter can be utilized for this application and the performance of these two converters as a pre-regulator for BLDC motor drive system is analyzed using Mat lab Simulink.

**Keywords:** BLDC motors, Diode Bridge Rectifier, Power Factor, Luo converter and Ultra Luo converter.

### I. Introduction

Every system we see around us in motion relies on some form of Motor drive systems. Power electronics play a great role in making these motor drives more efficient and controllable for different applications we usually encounter in day to day life both in household and industrial environments. When we consider valuable benefits like high power density, high efficiency, high ruggedness, compact size, immunity to electro-magnetic interference and their low maintenance requirements the Brushless DC (BLDC) motors comparing to the conventional induction motors have become increasingly popular mainly in medium and low power applications. In a BLDC motor drive we use a front-end diode bridge rectifier (DBR) and a high value DC link capacitor. The Power factor of such an arrangement will be well below unity power since the DC link capacitor draws a highly distorted current which is rich in harmonics. Such configuration leads to a very low power factor of the order of 0.72 and high total harmonic distortion (THD) of supply current at AC mains which are not acceptable under the limits of international power quality standards such as IEC 61000-3-2. Moreover, such power quality indices also increase the EMI in the PFC converter. These EMI's are classified into two categories as conducted and radiated EMI, respectively. At lower frequencies, the EMI is primarily caused by the conduction and at higher frequencies; the EMI is caused by the radiation. Such EMI causes problems such as skin effect, high overshoot transients, hysteresis loss, eddy current loss and voltage drop which affect the overall efficiency and performance of the system. Therefore, improved power quality converters are used for improving the power quality at AC mains which also reduce such EMI problems. An improved power quality converters can be designed to operate in either continuous conduction mode or discontinuous conduction mode of operation. A continuous conduction mode offers an advantage of lower stress on a Power factor corrector converter switch, but requires a two control loops (i.e. voltage and current control loops) for achieving a DC link voltage control with PFC at AC mains. This requires three sensors for the operation, which is a costly option, and hence preferred for high power ratings (1kW). Whereas, the converter operating in DCM acts as an inherent power factor corrector and hence requires a single voltage control loop (i.e. single voltage sensor) for DC link voltage control. However, a higher stress on PFC converter switch is obtained in a PFC converter operating in discontinuous inductor current mode (DICM); hence this mode is preferred for low power applications. [1]-[3],[4]

A Luo converter can be used as a pre regulator circuit to improve the power factor. Luo converter have an additional characteristics of voltage lifting capability. Many versions of Luo converter voltage lifting technique such as re-lift. Super-lift and ultra-lift have been reported in the literatures. We analyze the

performance of a bridge type Luo converter and bridge type Ultra Luo converter as a pre-regulator with the help of Math lab Simulink models.[5]

## II. Motor Drive

### a. Motor Drive System

An electric motor is a device that converts electrical energy to mechanical energy. It also can be viewed as a device that transfers energy from an electrical source to a mechanical load. The system in which the motor is located and makes it spin is called the drive, also referred to as the electric drive or motor drive. The function of the motor drive is to draw electrical energy from the electrical source and supply electrical energy to the motor, such that the desired mechanical output is achieved. Typically, this is the speed of the motor, torque, and the position of the motor shaft. Figure 2.1 shows the block diagram of a motor drive.

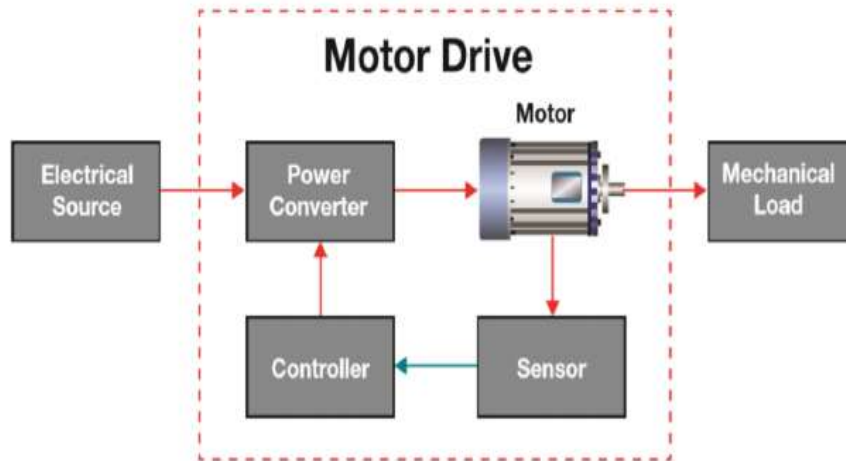


Fig.2.1 Block diagram of a motor drive system

The functions of the power converter circuit in the motor drive are: Transfer electrical energy from a source that could be of a given voltage, current at a certain frequency and phase as the input to an electrical output of desired voltage, current, frequency and phase to the motor such that the required mechanical output of the motor is achieved to drive the load. Controller regulates energy through feedback coming from the sensor block. Signals measured by sensors from the motor are low-power, which are then sent to the controller who tells the converter what it needs to be doing. A closed-loop feedback system is the method of comparing what is actually happening to what the motor should be outputting, then adjusting the output accordingly to maintain the target output. [1]-[2]

## III. Power Factor Correction

The Power Factor Pre-regulator is a circuit which is connected in along with Diode bridge rectifier in order to keep the line current approximately sinusoidal. The Power Factor Pre-regulator is also commonly known as a PFC, which stands for Power Factor Correction. The Power factor correction is merely said to be improving power factor which can be divided into two components displacement power factor and distortion power factor. The displacement power factor is the power factor due to the phase shift between voltage and current at the fundamental line frequency for sinusoidal (non-distorted) currents. But with the increase in non-linear loads such as inverters, drives, etc. the displacement power factor alone is not adequate. This is because the harmonics have an impact on the true power factor which is the product of displacement power factor and distortion power factor.

$$\text{True Power Factor} = \text{Displacement Power Factor} * \text{Distortion Power Factor} \quad (3.1)$$

Typical distortion power factor of a full wave rectifier with no inductor is in the range of 55% to 65%, and is governed by ac system inductance. The low value of distortion power factor at discontinuous conduction modes of converter circuits brings up the idea of an electric circuit, which would improve the power factor: and thus the idea of Power Factor Correction (PFC) circuits is started to be utilized.[6]

#### IV. Luo Converters

##### a. PFC Bridge type Luo converter

In PFC Bridge type Luo converter circuit, The Diode bridge rectifier will rectify the input AC waveform to DC waveform and the Luo converter is designed and connected as a Power Factor Correction pre regulator. [6]

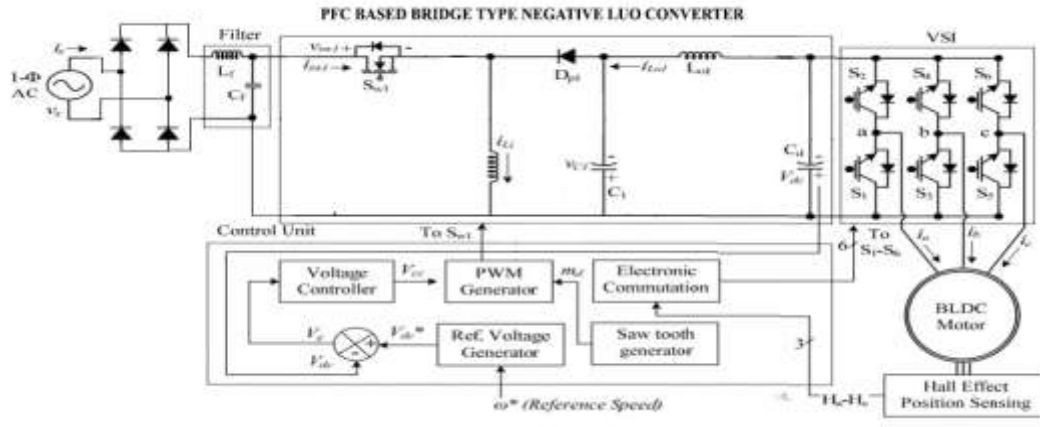


Fig.4.1 PFC based Bridge type Negative-Luo converter fed BLDC motor drive

##### b. PFC Bridge type Ultra Luo converter

In PFC Bridge type Ultra Luo converter circuit, The Diode bridge rectifier will rectify the input AC waveform to DC waveform and the Luo converter is designed and connected as a Power Factor Correction pre regulator similar to a normal negative Luo converter. [7]-[8]

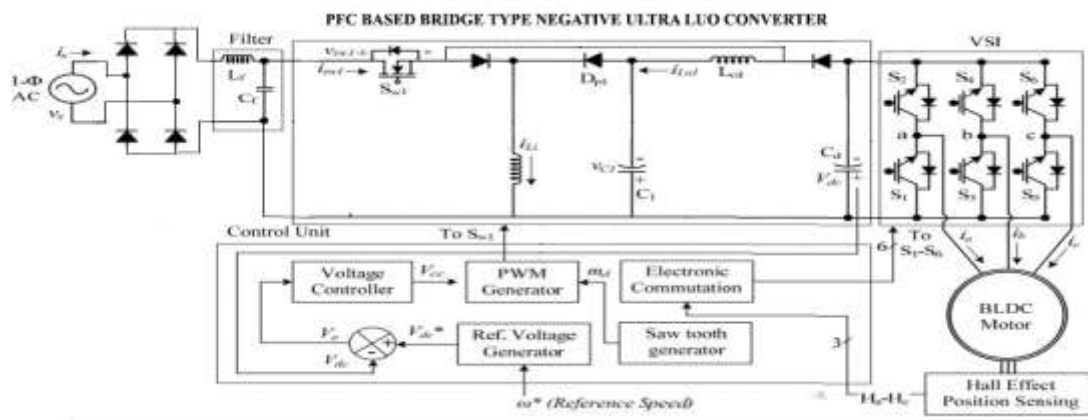


Fig.4.1 PFC based Bridge type Negative – Ultra Luo converter fed BLDC motor drive

#### V. Simulation Analysis Of Bridge Type Luo Converters

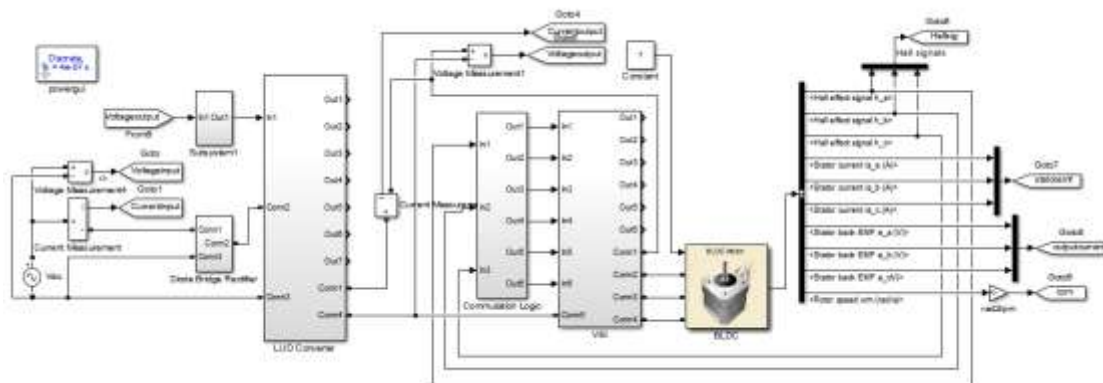
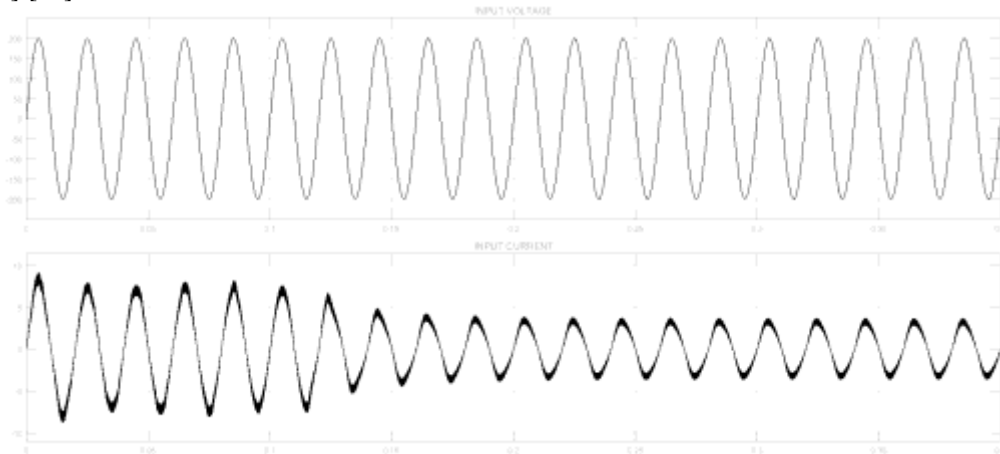


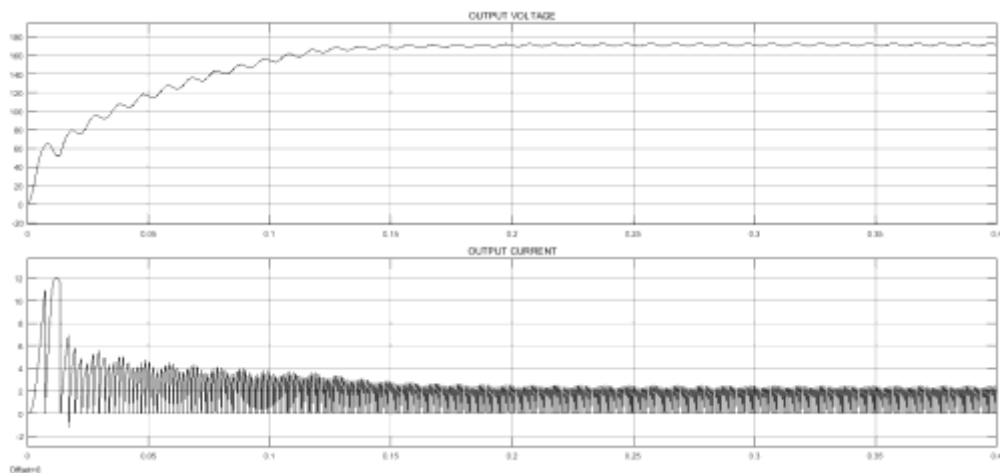
Fig.5.1 Simulation of PFC based Bridge type Negative – Luo converter fed BLDC motor drive

Using Mat lab Simulink software the Simulation analysis of Bridge type-Luo converter is done as shown in the Figure 5.1 Simulink model of Bridge type-Luo Converter fed motor drive.

Using this Simulink model several simulation analysis were done within the workable range of DC link Voltages  $V_{dcmin}$  and  $V_{dcmax}$  in order to analyze the working of PFC fed Bridge type-Luo BLDC motor drive .A set of reference speed like 2500rpm, 2000rpm and 1500rpm within the DC voltage range are applied on each iterative steps of simulation analysis done using Mat Lab Simulink, and at each of these iterative simulation analysis steps with set reference speed values corresponding input waveforms, output waveforms, Total Harmonic Distortion and PI controlled speed in rpm, etc. are collected and tabulated data is formed. The simulated data corresponding to 2500rpm reference speed are shown in the figures Fig 5.2, Fig 5.3, Fig 5.4 and Fig 5.5 [9]-[10]



**Fig.5.2** Input waveform of Bridge type Negative Luo converter at 2500rpm reference speed



**Fig.5.3** Output waveform of Bridge type Negative Luo converter at 2500rpm reference speed

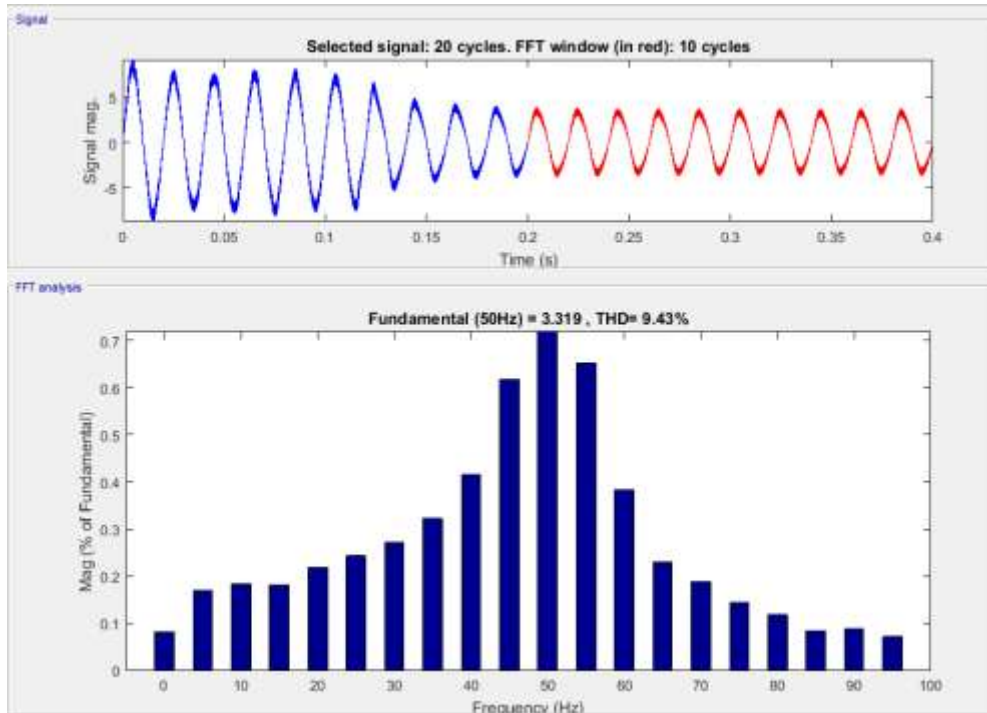


Fig.5.4 THD of input side current waveform of Bridge type Negative – Luo converter at 2500rpm reference speed

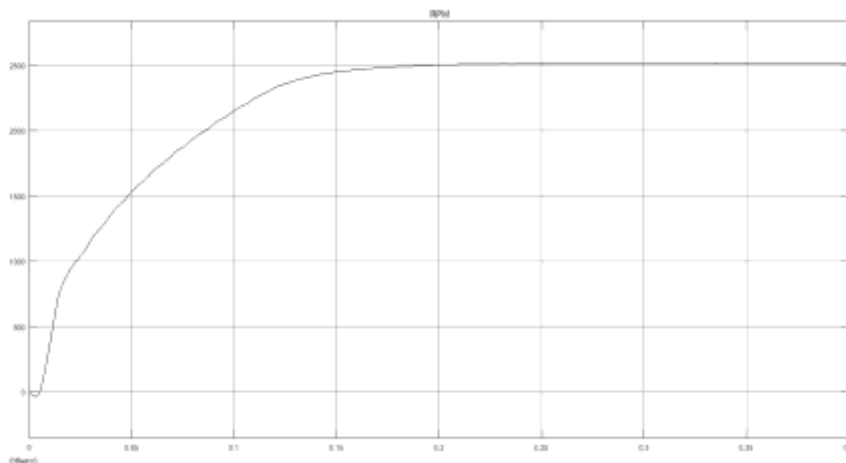
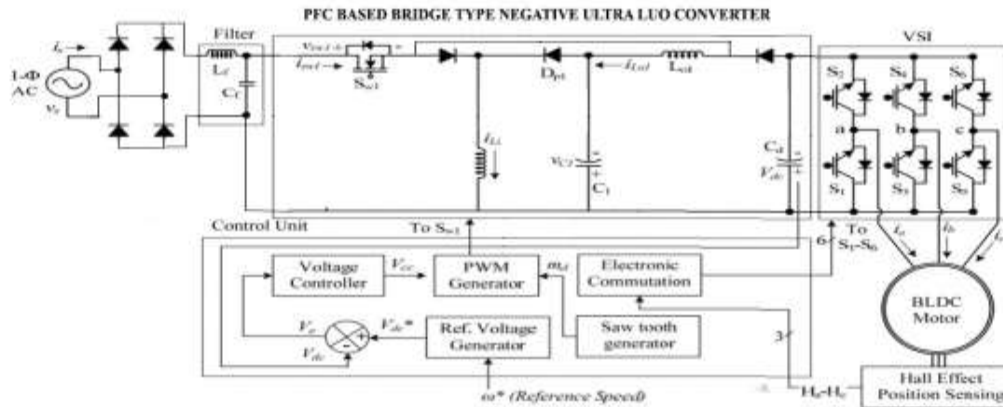


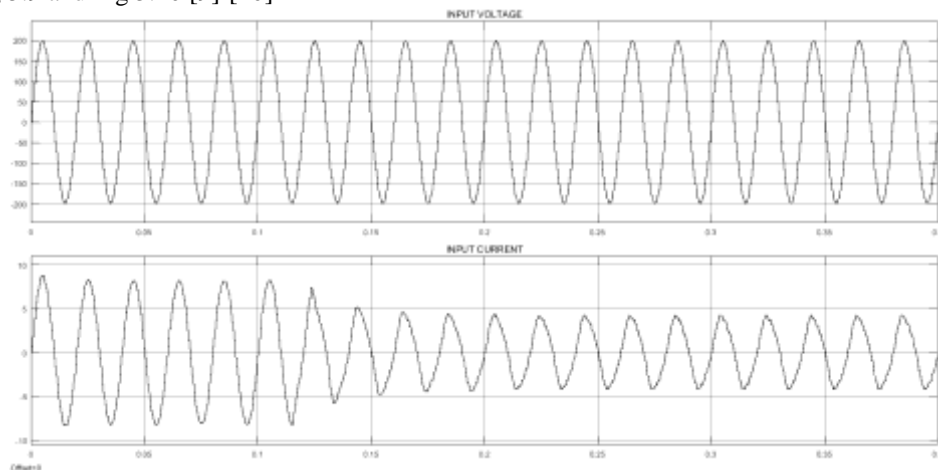
Fig.5.5 Speed in RPM of Bridge type Negative – Luo converter fed BLDC motor drive at 2500rpm reference speed

Similarly Using Mat lab Simulink software the Simulation analysis of Bridge type - Ultra Luo converter is done as shown in the Figure 5.6 Simulink model of Bridge type-Ultra Luo Converter fed motor drive.

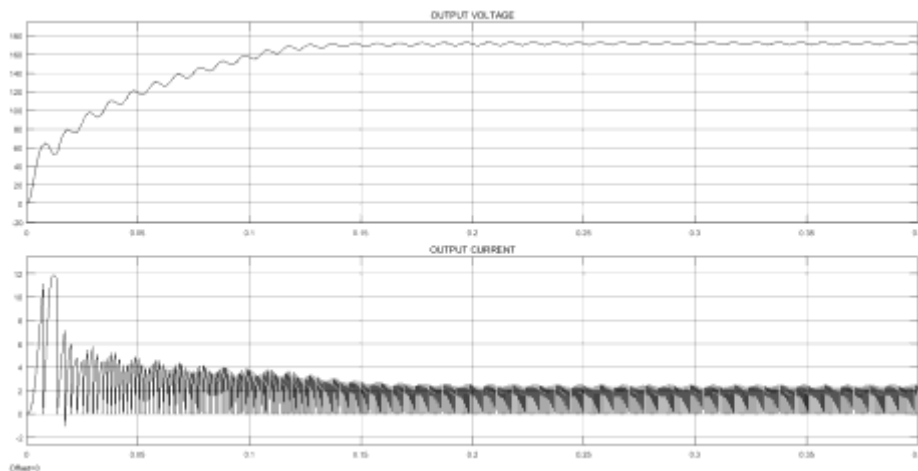


**Fig.5.6** Simulation of PFC based Bridge type Negative – Ultra Luo converter fed BLDC motor drive

Using this Simulink model several simulation analysis were done within the workable range of DC link Voltages  $V_{d_{min}}$  and  $V_{d_{max}}$  in order to analyze the working of PFC fed Bridge type-Ultra Luo BLDC motor drive .As we done for Luo converter set of reference speed like 2500rpm, 2000rpm and 1500rpm within the DC voltage range are applied on each iterative steps of simulation analysis done using Mat Lab Simulink, and at each of these iterative simulation analysis steps with set reference speed values corresponding input waveforms, output waveforms, Total Harmonic Distortion and PI controlled speed in rpm, etc. are collected and tabulated data is formed. The simulated data corresponding to 2500rpm reference speed are shown in the figures Fig 5.7, Fig 5.8, Fig 5.9 and Fig 5.10 [9]-[10]



**Fig.5.7** Input waveform of Bridge type Negative Ultra Luo converter at 2500rpm reference speed



**Fig.5.8** Output waveform of Bridge type Negative Ultra Luo converter at 2500rpm reference speed

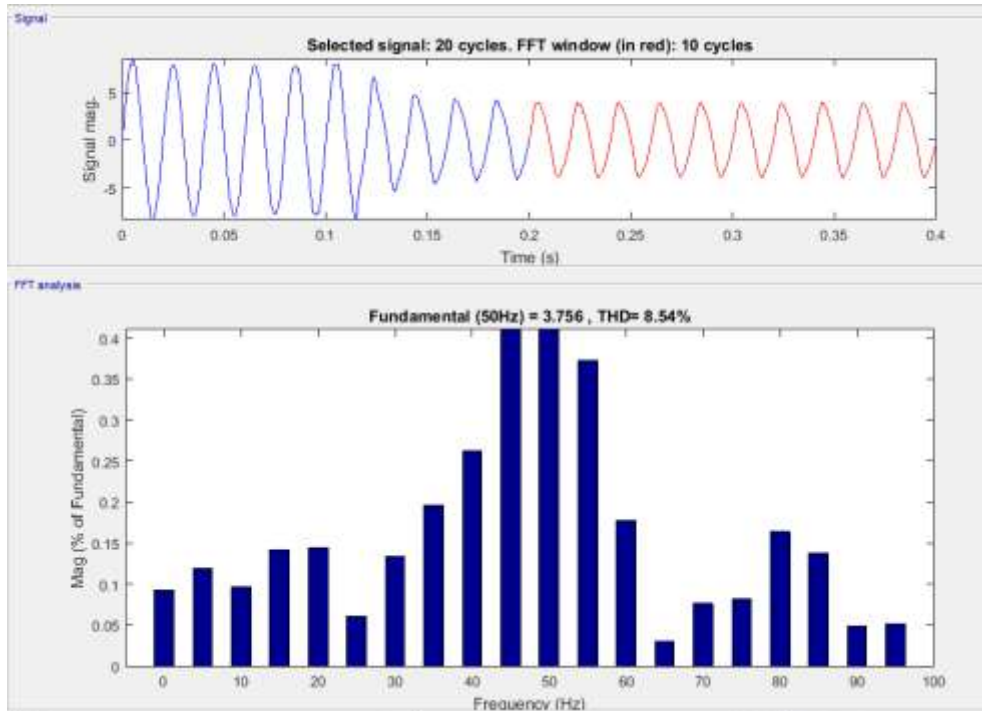


Fig.5.9 THD of input side current waveform of Bridge type Negative – Ultra Luo converter at 2500rpm reference speed

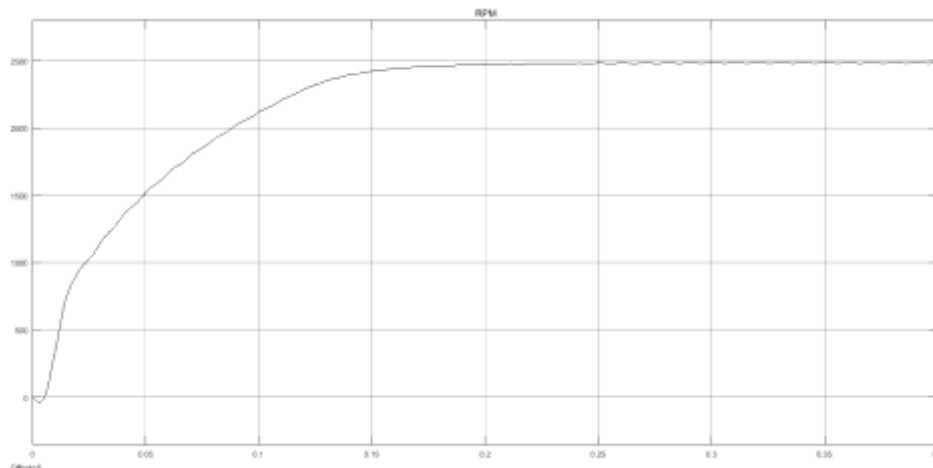


Fig.5.10 Speed in RPM of Bridge type Negative – Ultra Luo converter fed BLDC motor drive at 2500rpm reference speed

Table 5.1 Simulated Data Of Bridge Type Luo Converter And Bridge type Ultra Luo Converter

Bridge type Luo Converter								
RPM ref	Input Voltage	Input Current	THD	DC link Voltage	DC link Current	RPM	Power Factor	Average THD
2500	200	3.7	9.43%	173	2.5	2482	0.99	22.43%
2000	200	3.2	21.56%	139	2.5	1984	0.96	
1500	200	2.9	36.30%	104	2.5	1476	0.91	
Bridge type Ultra Luo Converter								
RPM ref	Input Voltage	Input Current	THD	DC link Voltage	DC link current	RPM	Power Factor	Average THD
2500	200	4.2	8.54%	170	2.5	2446	0.99	16.26%
2000	200	3.2	13.15%	138	2.5	1997	0.98	
1500	200	2.5	27.10%	105	2.5	1490	0.93	

## **VI. Conclusion**

Using The Mat Lab Simulink Analysis Done On Both Bridge Type Luo Converter And Bridge Type Ultra Luo Converter At Different Set Reference Speed Like 2500rpm, 2000rpm And 1500rpm Corresponding Data's Like Input Waveforms, Output Waveforms, Total Harmonic Distortion And PI Controlled Speed In Rpm, Etc. Are Collected And Tabulated As Shown In The Table 5.1. From This In The View THD Performance We Can Conclude That Bridge Type-Negative Ultra Luo Converter Is Showing Better Performance Than The Bridge Type Normal Negative Luo Converter.

## **References**

- [1] C. L. Xia, Permanent Magnet Brushless DC Motor Drives and Controls, Wiley Press, Beijing, 2012.
- [2] T. Kenjo and S. Nagamori, Permanent Magnet Brushless DC Motors, Clarendon Press, Oxford, 1985.
- [3] R. Krishnan, Electric Motor Drives: Modeling, Analysis and Control, Pearson Education, India, 2001.
- [4] Limits for Harmonic Current Emissions (Equipment input current 16A per phase), International Standard IEC 61000-3-2, 2000
- [5] B. Singh, V. Bist, A. Chandra and K. Al-Haddad, Power Factor Correction in Bridgeless-Luo Converter-Fed BLDC Motor Drive, IEEE Transactions on Industry Applications, vol. 51, no. 2, pp. 11791188, March-April 2015.
- [6] A. Emadi, A. Khaligh, Z. Nie, and Y. Joo Lee: Integrated Power Electronic Converters and Digital Control. Chapter 3: Power Factor Correction CRC Press 2009.
- [7] F. L. Luo, "Negative output Luo converters: voltage lift technique," in IEE Proceedings - Electric Power Applications, vol. 146, no. 2, pp. 208-224, Mar 1999.
- [8] Fang Lin Luo and Hong Ye, "Ultra-lift Luo-converter," 2004 International Conference on Power System Technology, 2004.
- [9] T. Y. Ho, M. S. Chen, L. H. Yang and W. L. Lin, The Design of a High Power Factor Brushless DC Motor Drive, 2012 Int. Sympo. Computer, Consumer and Control, pp. 345-348, 4-6 June 2012.
- [10] B. Tibor, V. Fedk and F. Durovsk, "Modeling and simulation of the BLDC motor in MATLAB GUI," 2011 IEEE International Symposium on Industrial Electronics, Gdansk, 2011, pp. 1403-1407.